

# 2024 EUROPEAN MASTERS CHAMPIONSHIP

SOCIETÀ VELA OSCAR COSULICH  
MONFALCONE  
SEPTEMBER 12<sup>th</sup>/15<sup>th</sup> 2024

## SAILING INSTRUCTIONS

SNIPE CLASS INTERNATIONAL RACING ASSOCIATION

[SP] denotes a rule for which a standard penalty may be applied by the Race Committee or Technical Committee (*Changes rule RRS 63.1, A4 and A5*) without a hearing or a discretionary penalty applied by the Protest Committee with a hearing.  
[NP] denotes a rule that shall not be grounds for protests by a boat. This changes RRS 60.1(a)

### 1 RULES

---

1.1 See point 1 of NoR.

### 2 CHANGES TO SAILING INSTRUCTIONS

---

- 2.1 Any change to the sailing instructions will be posted on the Official Notice Board 3 hours before the warning signal for the first scheduled race on the day it will take effect, except that any change to the schedule of races will be posted by 8.00 pm on the day before it will take effect.
- 2.2 Any change or amendment to the Sailing Instructions shall be approved with the SCIRA Representative.

### 3 COMMUNICATIONS WITH COMPETITORS

---

3.1 Notices to competitors will be posted on the Official Notice Board online at <https://www.racingrulesofsailing.org/events/8948>

### 4. CODE OF CONDUCT

---

- 4.1 [DP] Competitors and support persons shall comply with reasonable requests from race officials.
- 4.2 [DP] Competitors and support persons shall place advertising provided by the organizing authority with care, seamanship, in accordance with any instructions for its use and without interfering with its functionality.



## 5 SIGNALS MADE ASHORE

---

- 5.1 Signals made ashore will be displayed at the Club flagpole, placed at the Headquarters of the OA.
- 5.2 When the “AP” race signal is displayed ashore with 2 sounds ‘1 minute’ is replaced with ‘not less than 60 minutes’ in the race signal “AP”. This changes Race Signals.
- 5.3 [DP] Flag D with one sound means ‘Boats shall not leave the shore until this signal is made. The warning signal will not be made before the scheduled time or less than 60 minutes after flag D is displayed.’
- 5.4 When the “N” race signal is displayed ashore with 3 sounds means “No race today”. This changes Race Signal.

## 6 SCHEDULE OF RACES

---

6.1

Date	Hour	Action
Thursday, September 12 <sup>th</sup>	09:00h – 13:00h 14:00h – 19:00h	Registration of participants and coaches and equipment control
Friday, September 13 <sup>th</sup>	09:00h – 11:00h	Registration of participants and coaches and equipment control
	11:00h 11:30h 13:00h	Opening ceremony Skipper team leaders and coaches meeting Races
	TBD	Races
Saturday, September 14 <sup>th</sup>	TBD	Races
Saturday, September 14 <sup>th</sup>	TBD After racing	Races Price giving

- 6.2 The scheduled time for the display of the first warning signal on Saturday and Sunday will be posted on the Official Notice Board by 20:00h of the previous day. In the absence of this announcement, the time of display of the warning signal will be that of the previous day.
- 6.3 **On Sunday, September 15<sup>th</sup>** no warning signal will be made after **16:00h**.
- 6.4 When the entrants exceed 75 boats, the fleet may be split, and the regatta will consist of a qualifying series and a final series.
- 6.5 No more than 2 races shall be sailed per day.

## 7 CLASS FLAGS

---

- 7.1 The official Class Flag shall be the Snipe Class flag, a Snipe silhouette on a white background.

## 8 RACING AREAS

---

- 8.1 The green areas indicated with 1 and 2 in Appendix A show the racing areas.



## 9 THE COURSES

- 9.1 The diagrams below show the courses, including the approximate angles between legs, and the order in which marks are to be passed. All course marks (except gates) shall be left to port.

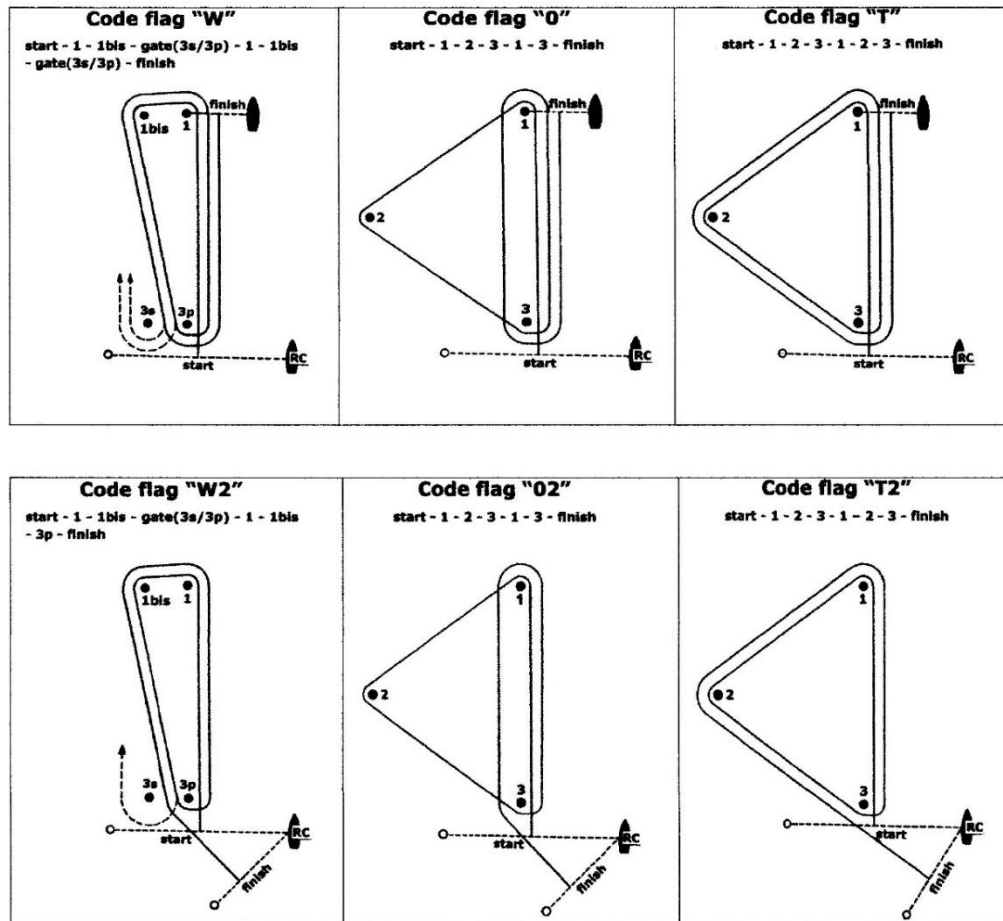

- 9.2 The course signal (code flag "W", "T", "O", "W2", "T2" or "O2") shall be displayed with one sound at last one minute before the warning signal. It will remain displayed for not less than five minutes after the start.
- 9.3 No later than the warning signal, the Race Committee signal boat may display the approximate compass bearing of the first leg.
- 9.4 If during a race the wind and/or wave action changes to the point where the selected course would be inadvisable (See Course Selection Diagram), the Race Committee shall change the course at any mark. A change of the type of course during the race shall be signalled displaying the new appropriate flag and accompanied by repetitive sounds before the leading boat has passed or rounded the mark.
- 9.5 A sustained wind variation of 20 degrees or more from the posted bearing during the first leg of a race shall result in the race to be abandoned and re-sailed or abandoned. This changes the RRS 32.1.
- 9.6 A sustained wind variation of 40 degrees or more from the posted bearing during the first lap shall result in the race being abandoned and re-sailed or abandoned. For the purpose of this rule, a lap means the rounding of mark 3 (or passing the gate 3s-3p) for the first time. This changes the RRS 32.1.



- 9.7 The number of legs in a race may be reduced (RRS code flag S) but at least 2 (two) windward legs of the course shall be completed. This changes the RRS 32.2.
- 9.8 The wind speed ranges shall be no less than 5 knots and not exceed 15 knots or in accordance with the Rules of Conduct for Conducting National and International Championships and the applicable Deed of Gift. This changes rule 32.1.

## **10 MARKS**

---

- 10.1 Marks 1, 1bis, 2, 3, 3s and 3p will be yellow inflatable cylindrical buoys.
- 10.2 New marks, as provided in instruction 13.1, will be orange inflatable cylindrical buoy.
- 10.3 The port-end starting mark will be:  
a) a boat with an orange flag displayed;  
or  
b) an orange inflatable cylindrical buoy.
- 10.4 The finishing mark will be:  
- mark 1 for “W”, “O”, and “T” courses;  
- a buoy with pole with BLUE flag for “W2”, “O2”, and “T2” courses.
- 10.5 Except at a gate, a Race Committee vessel signalling a change of a leg of the course is a mark as provided in SI 13.2.
- 10.6 If one of the marks "gate 3s-3p" is not placed, or is not replaced as per RRS 34, the remaining mark shall be left to port. This changes the RRS 34.
- 10.7 The new mark used for the change of the next leg of the course will be an orange inflatable cylindrical buoy.

## **11 AREAS THAT ARE OBSTRUCTIONS**

---

- 11.1 No obstructions areas on the race course

## **12 THE START**

---

- 12.1 The races will start as per Rule 26 with the warning signal given 5 minutes before the starting signal.
- 12.2 The starting line will be between a staff displaying an orange flag on the Race Committee vessel at the starboard end and:  
a) a staff displaying an orange flag on the starting mark as provided in instruction 10.3 a).  
or  
b) the course side of the starting mark as provided in instruction 10.3 b).
- 12.3 A boat starting later than 5 minutes after her starting signal will be scored Did Not Start without a hearing. This changes Appendices A4 and A5.
- 12.4 RRS 30.4 is changed so that it will be applied in fleets with more than 45 boats and after the 2<sup>nd</sup> General Recall for that race.
- 12.5 The Race Committee, after the finish of a race and before the warning signal of a subsequent one, will do its best to post on the Race Committee vessel a list of OCS, or ZPF, UFD or BFD boats. The failure of posting or an incomplete or wrong list will not be grounds for redress. This changes the RRS 62.1(a).
- 12.6 To alert boats that a race or sequence of races will begin soon, the orange starting line flag will be displayed with one sound at least 5 minutes before a warning signal is made.

## **13 CHANGE OF THE NEXT LEG OF THE COURSE**

---

- 13.1 To change the next leg of the course, the Race Committee will lay a new mark (or move the finishing line) and remove the original mark as soon as practicable. When in a subsequent change a new mark is replaced, it will be replaced by an original mark.
- 13.2 Except at a gate, boats shall pass between the race committee boat signalling the change of the next leg and the nearby mark, leaving the mark to port and the Race Committee vessel starboard. This changes the RRS 28.



- 13.3 After the completion of first windward leg of the race the remaining legs may be increased or decreased by not more than 30% of the original length. This changes the RRS 33.
- 13.4 If Mark 1 will be changed in courses “W” or “W2”, Mark 1bis (offset) will no longer be a course mark.

## **14 THE FINISH**

---

- 14.1 The finish line will be between a staff displaying a blue flag on a Race Committee vessel and the course side of the finishing mark.

## **15 TIME LIMITS AND TARGET TIMES**

---

- 15.1 The races will be managed to last 60-75 minutes for the first boat to finish. A different time (shorter or longer) used to complete the race will not be ground for requesting redress. This changes 62.1.
- 15.2 The time limit for the first boat to complete the first lap is 40 minutes from the start. If the first boat fails to complete the first lap within 40 minutes the Race Committee shall abandon the race. For the purpose of this rule a lap means the rounding of Mark 3 (or passing the Gate 3s/3p) for the first time.
- 15.3 The time limit for the first boat to finish the race shall be 1 hour, 30 minutes. Any boat finishing more than 30 minutes after the first boat finishes or failing to finish within 2 hours from the start, whichever is shorter shall be scored Did Not Finish (DNF). This changes RRS 35, A4 and A5.

## **16 HEARING REQUESTS**

---

- 16.1 Protest forms are available at the race office, located at <https://www.racingrulesofsailing.org/events/8948>. Protests and requests for redress or reopening shall be delivered there within the appropriate time limit.
- 16.2 The protest time limit is 90 minutes after the last boat has finished the last race of the day or the Race Committee signals no more racing today, whichever is later.
- 16.3 Notices will be posted no later than 30 minutes after the protest time limit to inform competitors of hearings in which they are parties or named as witnesses. Hearings will be held in the hearing room of the Headquarters of the OA beginning at the time posted.
- 16.4 Notices of protests by the Race Committee, Technical Committee or Protest Committee will be posted to inform boats under RRS 61.1(b).
- 16.5 The penalty for breaking rules in the SI marked with [SP] may be applied at the discretion of the Race Committee, without a hearing, and shall be the 5% scoring penalty for nearest race completed by the infringing boat but not worse than a DSQ. This changes the RRS 63.1 and the Appendix A5.
- 16.6 Penalties for breaking Class Rules may be less than disqualification. This changes 64.2.
- 16.7 Per Appendix N2.2, SCIRA reserves for itself the right and responsibility to decide issues of eligibility, measurement and equipment. SCIRA may refer any issue to the International Jury for advice.
- 16.8 For the purpose of RRS 64.4(b) the “authority responsible” is the Measurer of the event.
- 16.9 The Jury will abandon the race if, during a redress hearing, they conclude that the Race Committee did not follow Sailing Instructions 9.5, 9.6, 9.7, 9.8 and 13.3. This changes the RRS 64.3.
- 16.10 A list of boats that have been penalized for breaking RRS 42, RRS 29.1(OCS) or 30.1(OCS) or 30.2(ZPF) 30.3(UFD), 30.4 (BFD), will be posted on the Official Notice Board.
- 16.11 On the last scheduled racing day:
- a request of redress shall be delivered within the protest time limit or 30 minutes after incident occurred, whatever the latest deadline (changes RRS 62.2)
  - a request for reopening a hearing shall be delivered:
    - a) within the protest time limit if the requesting party was informed of the decision on the previous day (changes RRS 66);
    - b) no later than 30 minutes after the requesting party was informed of the decision on that day (changes RRS 66).



## 17 SCORING

---

- 17.1 **6 races are scheduled.** 3 races are required to be completed to constitute a series.
- 17.2 (a) When fewer than 5 races have been completed, a boat's series score will be the total of her race scores.  
(b) When from 5 to 6 races have been completed, a boat's series score will be the total of her race scores excluding her worst score.
- 17.3 A boat intending to retire and be scored RET shall report its intent in writing to the Race Committee or the Jury within the protest time limit.

## 18 [NP][DP] SAFETY REGULATIONS

---

- 18.1 Before the warning signal of the first race of the day each boat is required to sail past the stern of a Race Committee boat on starboard tack and verbally check in. The check-in boat will display the SVOC pennant while on station prior to the first warning signal. If no separate check-in boat is on station competitors will check in with the main Race Committee boat. When the Race Committee verbally acknowledges a boat's sail number, the check-in has been officially noted.
- 18.2 A boat that retires from a race (DNF) shall notify the Race Committee as soon as possible.

## 19 REPLACEMENT OF CREW OR EQUIPMENT

---

- 19.1 The same crew shall race in all races, except for reasons satisfactory to the Race Committee. Requests for a change of crew shall be submitted by racingrulesofsailing.org at <https://www.racingrulesofsailing.org/events/8948>. Once a crew has been excused, he/she may not return for the balance of the series.
- 19.2 The same skipper shall sail all races and can be replaced after the first race only, and then only if he/she is obviously incapacitated. If a skipper is replaced the first race will be scored DNC.
- 19.3 [DP] Substitution of hull, sails, appendages, and rig will not be allowed unless authorized in writing by the Race Committee. Requests for substitution shall be made to the Committee at the first reasonable opportunity, by racingrulesofsailing.org at <https://www.racingrulesofsailing.org/events/8948>, which may be after the race.

## 20 OFFICIAL VESSELS

---

- 20.1 Official boats will be marked as follows: white Flag with S and SVOC pennant.

## 21 [DP] RADIO COMMUNICATIONS

---

- 21.1 A boat that is racing shall not make voice or data transmissions and shall not receive voice or data communication that is not available to all boats, except in an emergency or when using equipment provided by the Race Committee.

## 22 [NP] [DP] TRASH DISPOSAL

---

- 22.1 Trash may be placed aboard support and Committee Vessels.

Signatures:

Sandro Fabietti, NRO (Ita) - Race Committee Chairman

Zbigniew Rakocy, COMMODORE (Pol) - SCIRA Representative



## APPENDIX A

Area nautica	Vertice	Latitudine	Longitudine
1 Baia di Panzano – Caregoni	A	45° 43. 9069' N	013° 34. 7917' E
	B	45° 45. 4702' N	013° 34. 8484' E
	C	45° 45. 8940' N	013° 34. 2600' E
	D	45° 45. 2580' N	013° 33. 1200' E
2 Baia Panzano – Marina Julia	E	45° 45, 9660' N	013° 34. 1520' E
	F	45° 45. 3360' N	013° 33. 0240' E
	G	45° 46. 0325' N	013° 32. 2477' E
	H	45° 46. 5893' N	013° 33. 2777' E
3 Cassa di Colmata	M	45° 45. 8601' N	013° 34. 8278' E
	N	45° 46. 5534' N	013° 33. 7721' E
	O	45° 46. 3594' N	013° 34. 8535' E

